

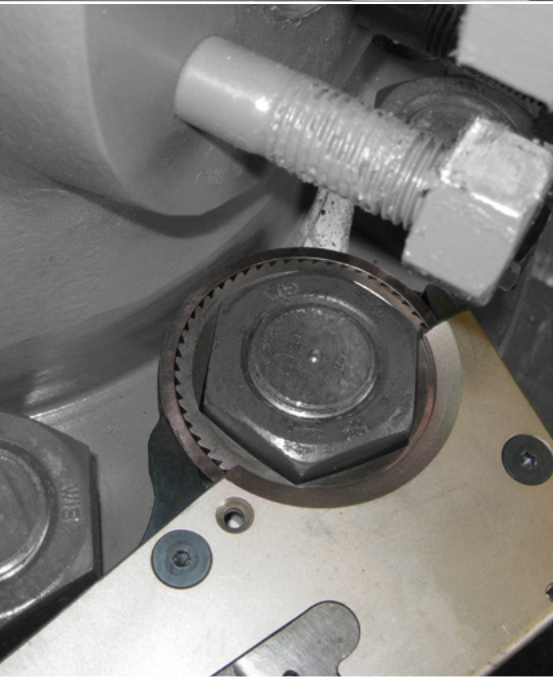

# TITAN<sup>®</sup>

BY CHICAGO PNEUMATIC



## SUPERTHIN<sup>®</sup> LINK

Unique Low Profile Hydraulic  
Torque Wrench



- ✓ **Extremely Low Profile**
- ✓ **Versatile**
- ✓ **Accurate**



[www.TITANti.com](http://www.TITANti.com)  
[www.cp.com](http://www.cp.com)

**People. Passion. Performance.**



### Over 110 years of experience

Since 1901 the Chicago Pneumatic (CP) name has represented reliability and attention to customer needs, with construction, maintenance and production tools and compressors designed for specific industrial applications. Today, CP has a global reach, with local distributors around the world.

To learn more about our extensive range of tools, construction equipment, industrial and portable compressors, accessories and workshop equipment, please visit [www.cp.com](http://www.cp.com).



### Titan is now part of Chicago Pneumatic

Since 2001, Titan products are in use every day in a wide variety of industries including oil & gas, mining and construction, power plants, shipyards, steel mills, locomotives, off-road equipment and cranes, and all types of industrial service companies supporting these market sectors. Titan hydraulic tools continually satisfy the demands of the industry during construction, production, breakdown, and routine shutdown repair and maintenance.

# LP Series SUPERTHIN® Link

## Extremely Low Profile Hydraulic Wrench

### LP SERIES MODULAR CONCEPT

- Compatible with the LP4 cylinder model

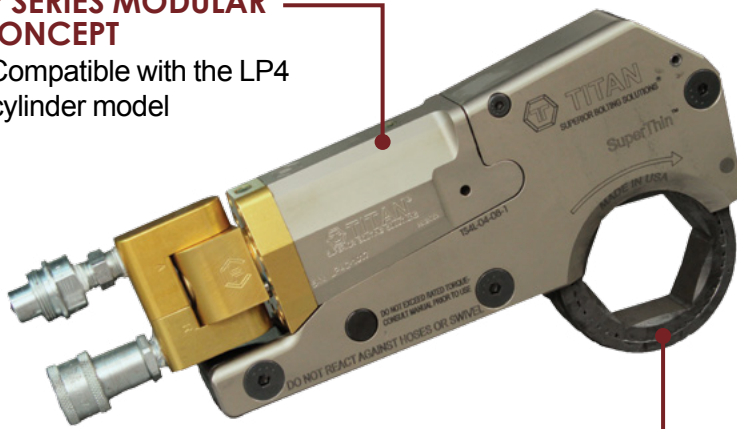

### SUPERTHIN LINK

- Fits where others can't: smallest link radius available today
- Extremely versatile
- Accurate: uses concentric straps around the bolt

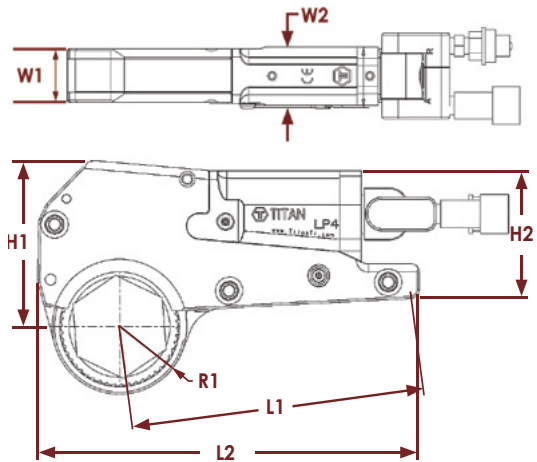

Dimensions		LP4ST
L1 - Maximum reaction reach	in / mm	8.41 / 213.69
L2 - Overall length	in / mm	10.7 / 271.78
H1 - Center of bolt to top of tool	in / mm	4.77 / 121.29
H2 - Back end height	in / mm	3.78 / 96.14
R1 - Tool radius around the bolt	in / mm	1.25 to 2.25 / 31.8 to 57.2
W1 - Tool width at link	in / mm	1 / 25.4
W2 - Tool width at cylinder	in / mm	1.75 / 44.45

Designed and developed for those very tight applications such as BOP bolting and other hard to access applications. The Titan SUPERTHIN link is made to deliver an accurate and repeatable torque in even the tightest applications.

The unique SUPERTHIN design uses a concentric strap instead of side plates to provide strength and accuracy. Where other tools can't fit, the SUPERTHIN easily fits and delivers reliable ratcheting, eliminating time-consuming and inaccurate bolting methods used in the past.

Specifications		LP4ST
Range of hex size	in / mm	1 13/16 to 3 1/8 / 46 to 80
Torque ft.lbs	min / max	390 / 2900
Torque Nm	min / max	530 / 3950
Cylinder weight	lbs. / kg	5.8 / 2.62
Range of link weight	lbs.	4.5 to 6.5
Range of link weight	kg	2 to 2.9

Pressure MAX: 8000 PSI (550 Bar)

Product reference / part number will vary depending on option choices.

Specifications are subject to change without notification. Please refer to your regional sales representative for more information.



[www.TITANti.com](http://www.TITANti.com)

[www.cp.com](http://www.cp.com)

English - 615 994 2701  
© Copyright 2015

The TITAN name and logo, as well as the SUPERTHIN name, are registered trademarks of Chicago Pneumatic Tool Company LLC.