

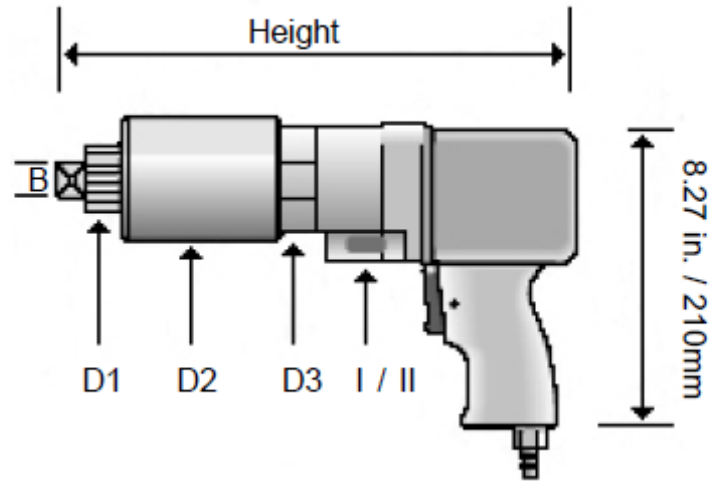

SUPERIOR BOLTING SOLUTIONS®

AT5800 F2

AirTite Pneumatic Torque Wrenches



AT5800 F2 AirTite F Series Two Speed:

Torque Range 1st Gear:	1973 – 5801 ft lb 2675 – 7865 nm	Height:	16.14 In 410 mm
Torque Range 2nd Gear:	620 – 1822 ft lb 1175 – 3455 nm	Free Speed (rpm):	1st gear 2 2nd gear 6
Square Drive (B):	1 1/2 In	Weight: (without support)	33.07 lb 15 kg
D1:	2.83 In 72 mm	5% Accurate Pressure Group:	15 ft. hose assy.
D2:	4.84 In 123 mm	Filter/Regulator/ Lubricator Assy:	Operaton/ Maintenance Manual
D3:	4.84 In 123 mm	Pressure to Torque Chart:	Supplied with Calibration Certificate
Mechanical selection switch- for power/run-down gear (AT-F2 gear):	QUIET - 66-78 dB(A)	Precise and Accurate +/-5%:	360 Degree Articulating Motor

(AirTite Seies Accessories Professional Pictures)

Accessories

ARA 24 72 DW	Deep Reaction Arm
ARA 24 72 CN	Crab Nut Reaction Arm
ARA 24 72 ML	Mill Liner/Extended Reaction Arm
SRA 24 72	Straight Reaction Arm
PSR 24 72	Splined Reaction Ring
SR 72	Sq. Dr. Extension 13"
ARA 24 72 DW	Safety Ring

SUPERIOR BOLTING SOLUTIONS®

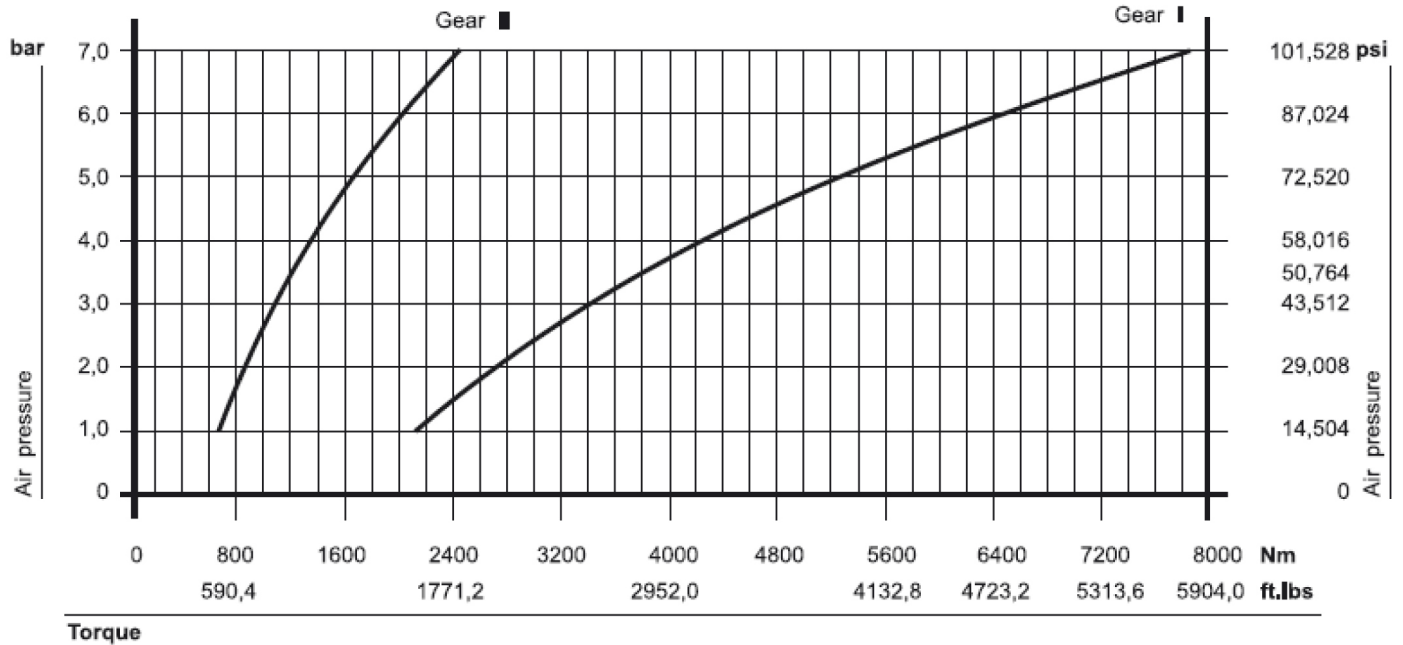

All curves are approximate values.
Unstable compressed air values can cause derivations.

Torque

Gear II	Nm	Ft Lbs
Bar	Max	Max
2	840	620
3	1065	784
4	1344	991
5	1645	1214
6	2015	1487
7	2470	1821

Gear I	Nm	Ft Lbs
Bar	Max	Max
2	2675	1973
3	3385	2496
4	4280	3157
5	5245	3867
6	6420	4736
7	7865	5801

Operating pressure on the machine
Air consumption: 21 – 32 cfm.