

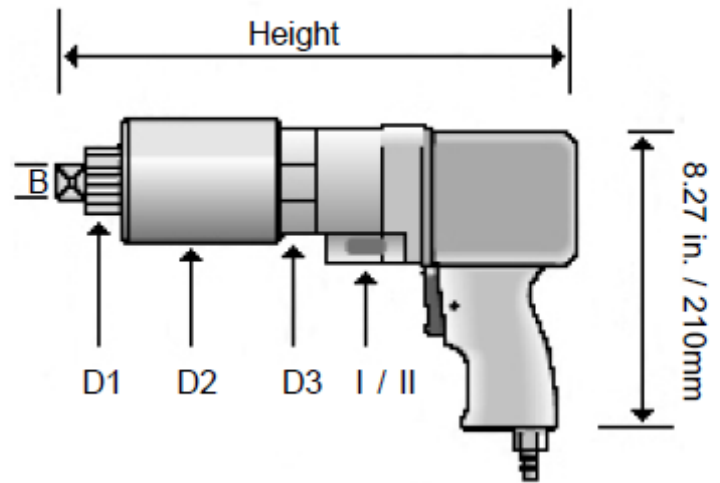

SUPERIOR BOLTING SOLUTIONS®

AT700 F2

AirTite Pneumatic Torque Wrenches



AirTite F2-Series Two Speed

Torque Range 1st Gear:	2368 – 6959 ft lb 3210 – 9435 nm	Height:	16.14 In 410 mm
Torque Range 2nd Gear:	745 – 2039 ft lb 1010 2765 nm	Free Speed (rpm):	1st gear 1.5 2nd gear 5
Square Drive (B):	1 1/2 In	Weight: (without support)	44.09 lb 20 kg
D1	2.83 In 72 mm	5% Accurate Pressure Group:	15 ft. hose assy.
D2	5.83 In 148 mm	Filter/Regulator/ Lubricator Assy:	15 ft. hose assy.
D3	5.83 In 148 mm	Pressure to Torque Chart:	Operaton/ Maintenance Manual
Mechanical selection switch- for power/run-down gear (AT-F2 gear)	QUIET - 66-78 dB(A)	Precise and Accurate +/-5%:	360 Degree Articulating Motor

(AirTite Seies Accessories Professional Pictures)

Accessories

ARA 24 72 DW	Deep Reaction Arm
ARA 24 72 CN	Crab Nut Reaction Arm
ARA 24 72 ML	Mill Liner/Extended Reaction Arm
SRA 24 72	Straight Reaction Arm
PSR 25-72	Splined Reaction Ring
SR 72	Sq. Dr. Extension 13"
ARA 24 72 DW	Safety Ring

SUPERIOR BOLTING SOLUTIONS®

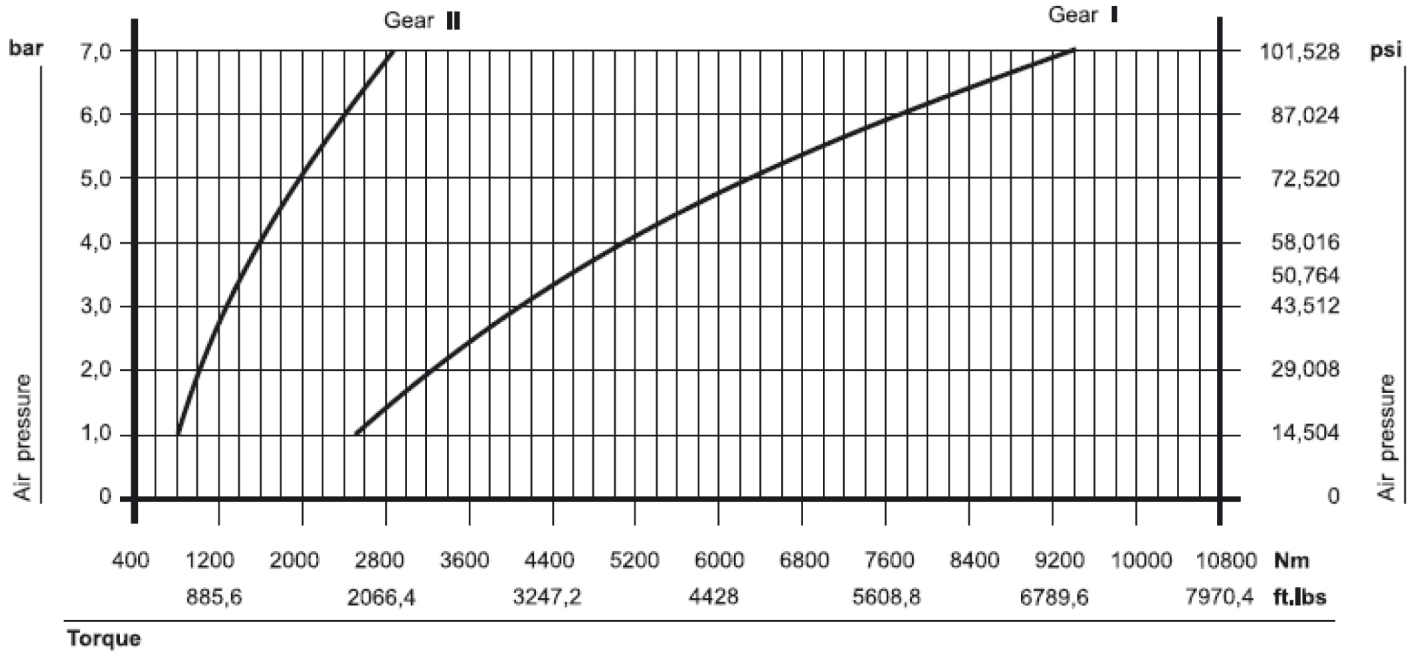

All curves are approximate values.
Unstable compressed air values can cause derivations.

Torque

Gear I	Nm	Ft Lbs
Bar	Max	Max
2	1010	744
3	1275	940
4	1615	1190
5	1975	1457
6	2420	1784
7	2965	2185

Gear II	Nm	Ft Lbs
Bar	Max	Max
2	3210	2368
3	4060	2995
4	5135	3789
5	6290	4640
6	7705	5683
7	9435	6961

Operating pressure on the machine
Air consumption: 21 – 32 cfm.