

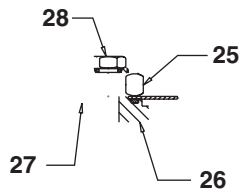

TITAN P+
HYDRAULIC PUMP
AIR DRIVEN WITH REMOTE CONTROL
GENERAL ASS'Y SIDE VIEW

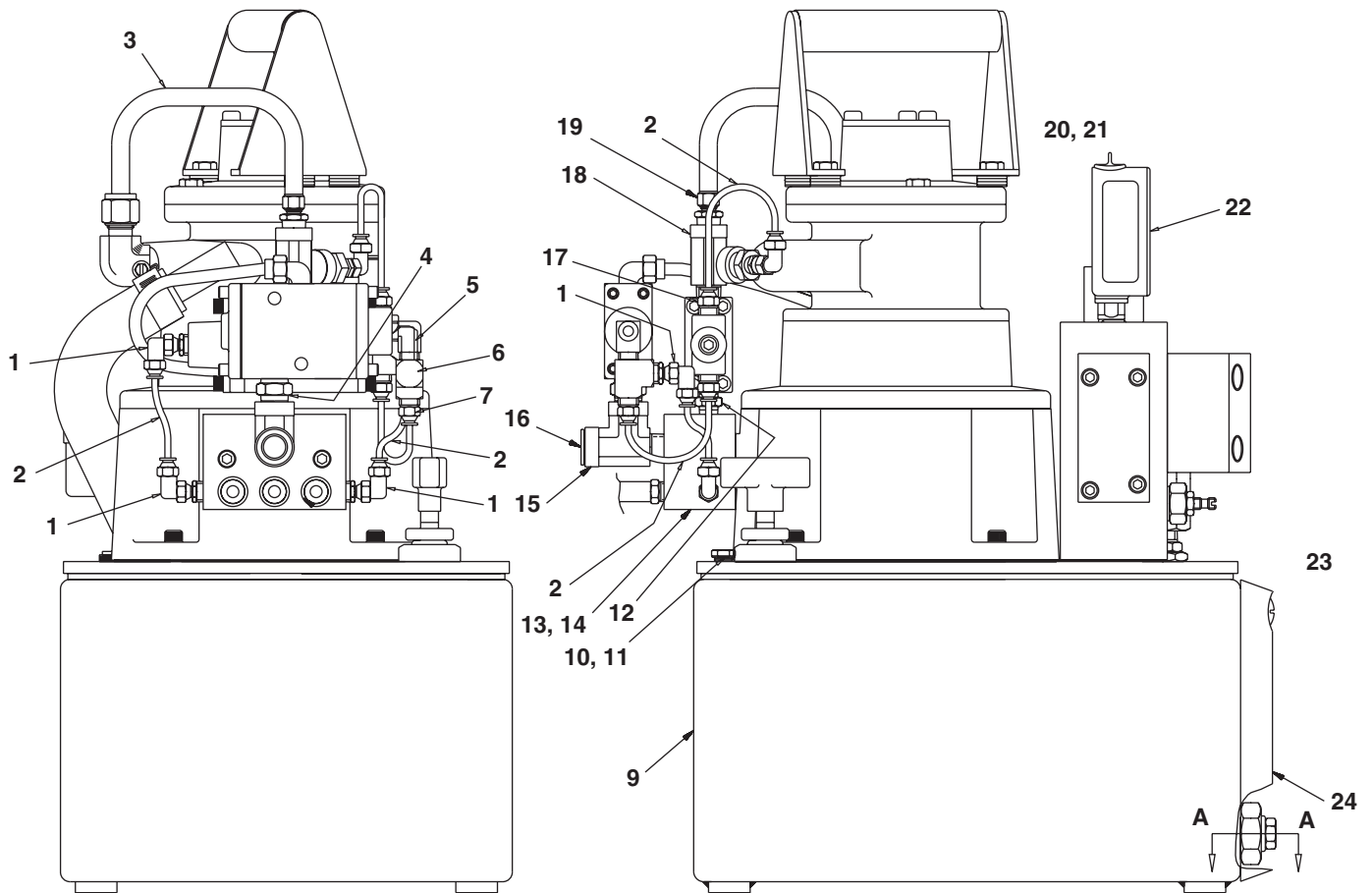

SECTION A-A

Part List, Form No. 1000163, Back sheet 1 of 6

Item No.	Part No.	No. Req'd	Description	Item No.	Part No.	No. Req'd	Description
1	250804	5	90° Elbow Fitting, 1/8 NPTF	14	10020	2	Cap Screw (1/4-20 X 1-1/4 Lg.)
2	14281	.8 ft.	Nylon Tubing	15	10623	1	Tee Fitting (3/8 NPTF)
3	2000397	1	Tube	16	11967	1	Plug, Tapered Cap
4	12328	1	Straight Fitting (NOTE: Install #12328 Fitting into #10623 Tee Fitting. Install 1/4 NPTF end of #12328 into Port No. 3 of #306033 Air Valve.)	17	250726	3	Straight Fitting(1/8 NPTF)
5	14680	1	90° Elbow Fitting, 1/8 NPTF	18	10618	1	Tee Fitting (1/4 NPTF)
6	19463	1	Tee Fitting 1/8 NPTF	19	17634	1	Straight Fitting (1/4 NPTF)
7	250726	1	Straight Fitting 1/8 NPTF	20	*51159	1	Air Motor Ass'y (See back sheet 2 of 6)
8	309219	2	Decal, Tradename Power Team	21	251206	1	Coupling
9	65599OR9	1	Reservoir	22	9040	1	Gauge, (10,000 psi 2-1/2" Dia.)
10	12825	1	Screw, Hex Hd Cap (1/4-20 x 5/8)	23	40164	1	Gasket, Reservoir
11	10442	1	Washer, Copper (.37 x .25)	24	350431	1	Gauge, Oil Level (w/thermometer)
12	16494	1	Straight Fitting 1/4 NPTF	25	10396	1	Nut, Hex Jam (3/4-16)
13	350244	1	Air Valve Manifold	26	351000	1	Drain
				27	14725	1	O-Ring (-119) Nitrile 1.12 x .93)
				28	17147	1	Plug Fitting (7/16 Hex 4-p50n-s)

***Note: For air motor repair kit, order no. 252100.**

HYDRAULIC SCHEMATIC

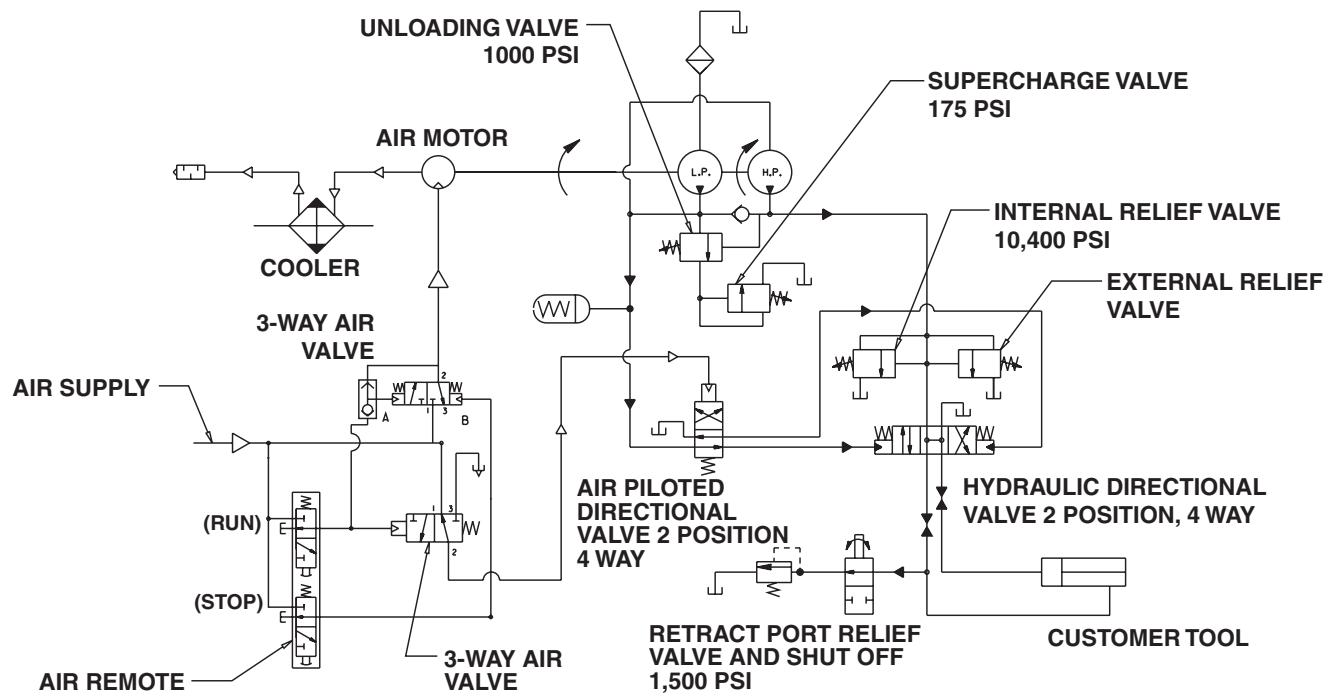

GENERAL ASS'Y TOP VIEW

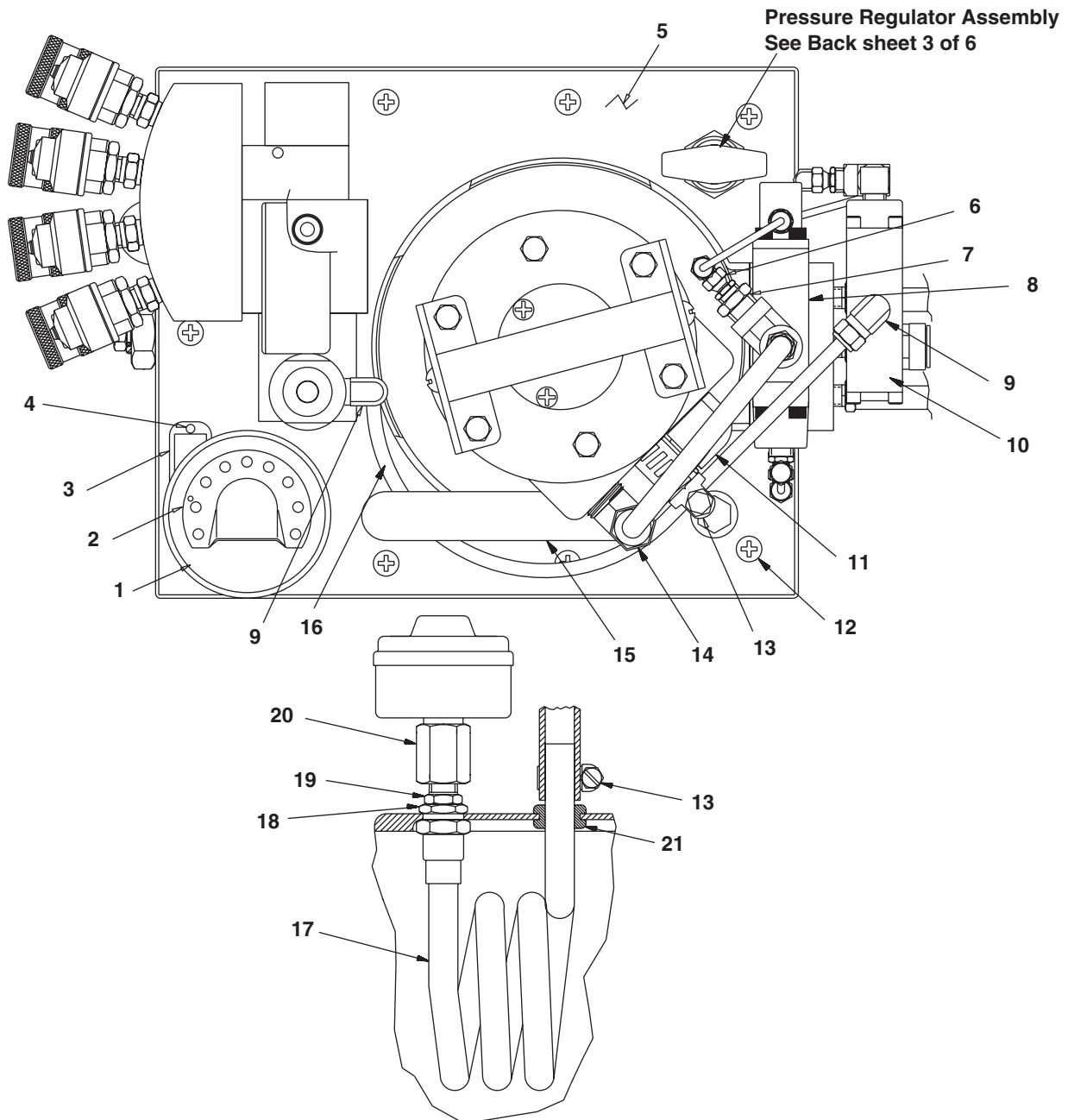

Item No.	Part No.	No. Req'd	Description	Item No.	Part No.	No. Req'd	Description
1	13966	1	Muffler	12	10177	9	Screw (1/4-10 X 7/8 Lg.)
2	205505	1	Muffler Deflector	13	12367	2	Hose Clamp
3	251906	1	Plate, Product Name	14	17636	1	90° Elbow Fitting, 1/2 NPTF
4	10575	4	Drive Screw	15	212898	.9ft.	Pressure Hose
5	3000227	1	Cover Plate Assembly	16	15883	1.4ft.	Tubing, Polyethylene
6	250804	1	90° Elbow Fitting, 1/8 NPTF	17	46626	1	Heat Exchanger Coil
7	13269	1	Straight Fitting 1/4 NPTF	18	251796	1	Jam Nut
8	2000383	1	Oil Level / Thermometer Gauge	19	251795	1	Straight Fitting
9	15457	2	90° Elbow Fitting	20	252240	1	Straight Fitting (1/2 x 1/2 BSPP)
10	212404	1	Valve, Air Operated 3-Way	21	212896	1	Grommet
11	212897	1	90° Elbow Fitting, 1/2 NPTF				

AIR MOTOR ASSEMBLY

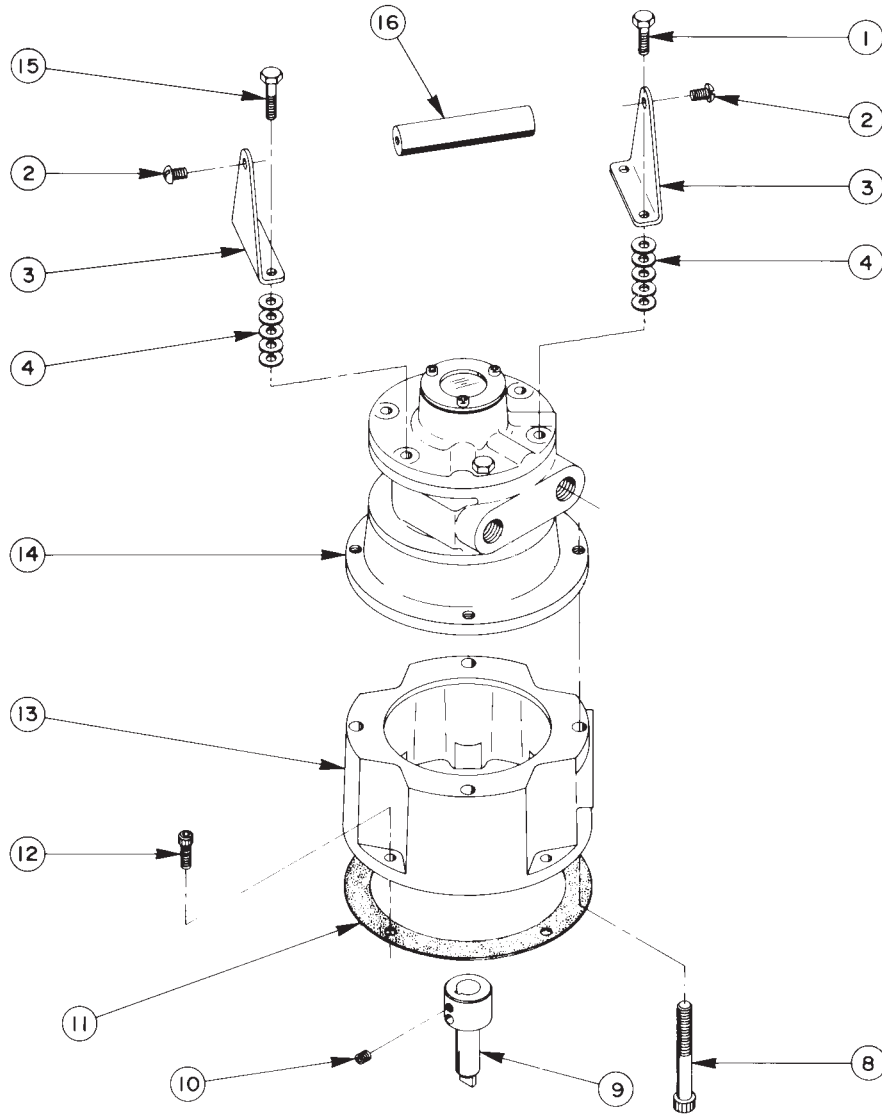

Item No.	Part No.	No. Req'd	Description
1	10014	1	Cap Screw (1/4-28 X 1" Lg.)
2	10174	2	Machine Screw (1/4-20 X 1/2 Lg.)
3	33808	2	Handle Bracket
4	12719	20	Washer
8	17816	4	Cap Screw (3/8-16 X 3" Lg.)
9	37842	1	Shaft Extension
10	10556	1	Set Screw (1/4-20 UNC X 1/4 Lg.)
11	30650	1	Gasket

Item No.	Part No.	No. Req'd	Description
12	10008	4	Cap Screw (1/4-20 X 3/4 Lg.)
13	51158WH2	1	Motor Base
14	*14717	1	Air Motor (See Form #16138)
15	10018	3	Cap Screw (1/4-28 X 1-1/4 Lg.)
16	28158	1	Handle
	51159	1	Complete Air Motor Ass'y (Includes Items 1 through 16)

*Note: For air motor repair kit, order no. 252100.

GENERAL PUMP ASSEMBLY

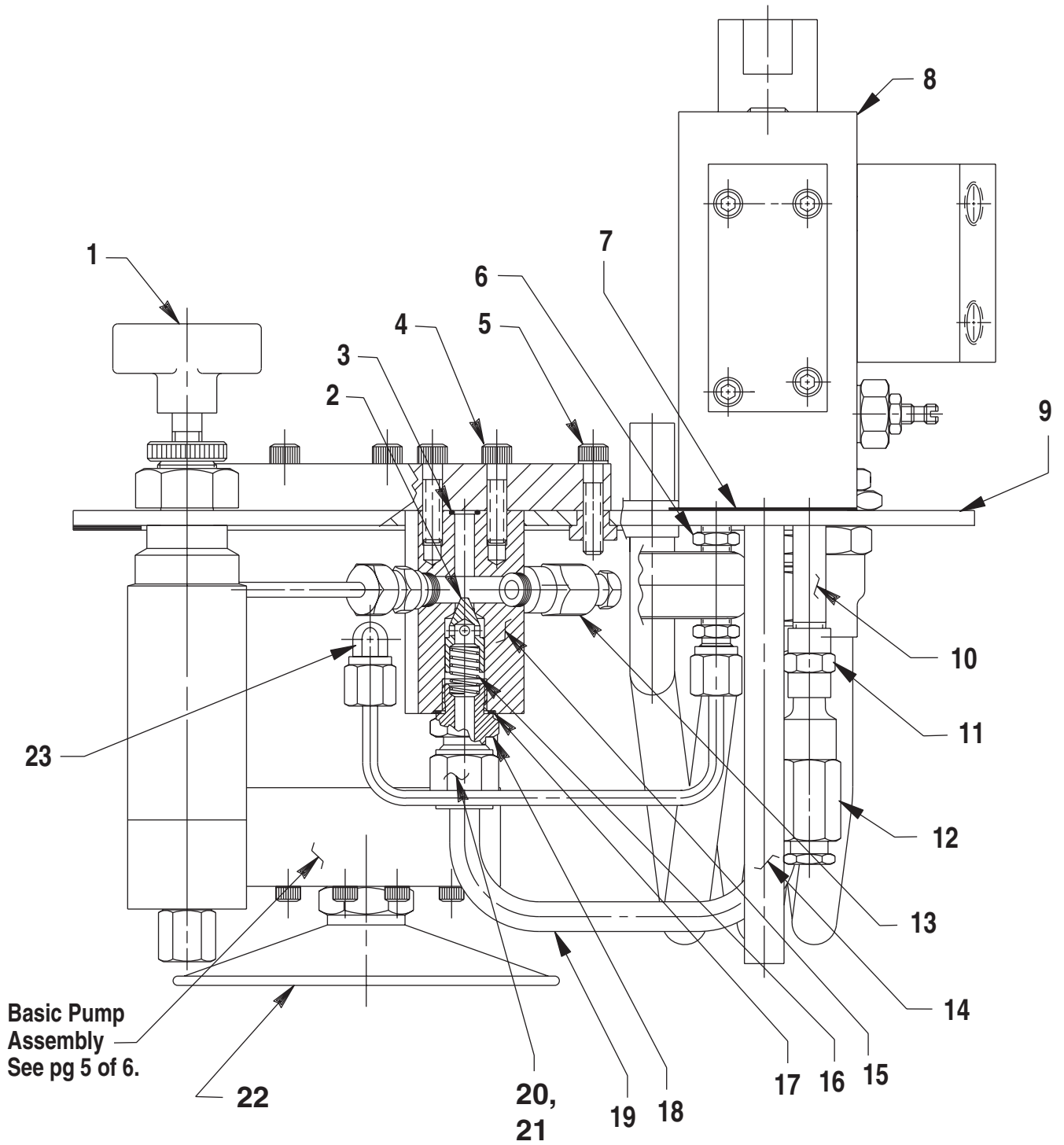

Parts List, Form No. 1000163, Back sheet 3 of 6

Item No.	Part No.	No. Req'd	Description
1	421280	1	Pressure Regulator Assembly (See parts listed below)
2	20771	1	Poppet
3	10266	1	O-ring (3/8 X 1/4 X 1/16)
4	10015	2	Hex Soc. Screw (1/4-28 UNF X 1" Lg.; Torque to 130/180 in. lbs.)
5	10016	3	Hex Soc. Screw (1/4-20 UNC X 1" Lg.)
6	11421	1	Straight Fitting
7	351095	1	Gasket
8	3000226	1	Valve Assembly
9	65186BK2	1	Cover Plate (See Sheet 6 of 6)
10	15456	1	Straight Fitting
11	18841	1	Straight Fitting
12	21278-15	1	Relief Valve (Set at 1,500/1,700 PSI)

Item No.	Part No.	No. Req'd	Description
13	21278	1	Relief Valve (Set at 10,100/10,700 PSI)
14	200609	1	Drain Tube
15	20776	1	Valve Body
16	10425	1	Spring (3/8 O.D. X 3/4 Lg.)
17	10261	1	Special Washer (3/4 X 19/32 X 1/32)
18	20770	1	Connector Fitting (Torque to 40/50 ft. lbs.)
19	252117	1	Oil Line
20	10430	1	Tube Sleeve
21	10431	1	Nut Fitting (3/8 Tube)
22	21345	1	Filter Screen (Includes o-rings)
23	11278	1	90° Elbow Fitting

PRESSURE REGULATOR ASSEMBLY

NOTE: Set at 10,100/10,700 PSI

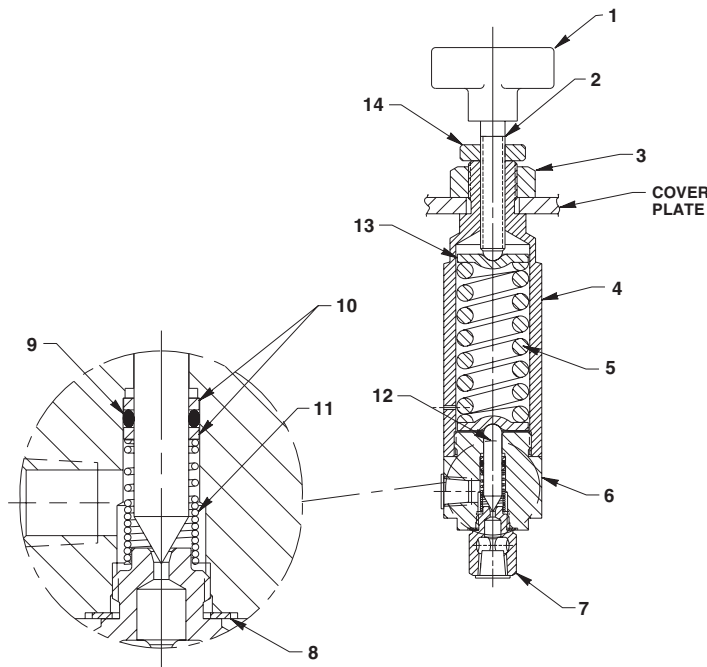

Item No.	Part No.	No. Req'd	Description
1	215693	1	Knob (Note: Assemble to stem [Item #2] with Loctite #242 or equiv.)
2	215721	1	Adjustment Stem
3	10396	1	Jam Nut (3/4-16 UNF)
4	309077	1	Regulator Housing
5	215429	1	Compression Spring (1.100 O.D. X 2-1/2 Lg.)
6	420891	1	Regulator Body
7	350944	1	Seat Fitting (Torque to 440/460 in. lbs.)

Item No.	Part No.	No. Req'd	Description
8	14874	1	Washer (.700 X 1/2 X 1/32)
9	10266	1	O-ring (3/8 X 1/4 X 1/16)
10	215430	2	Backup Washer
11	215431	1	Spring (Note: Assemble closed coils of spring form towards seat fitting [Item #7])
12	309079	1	Poppet
13	215428	2	Spring Retainer (Grease pocket before assembling [both ends])
14	215683	1	Regulator Locking Nut

BASIC PUMP ASS'Y

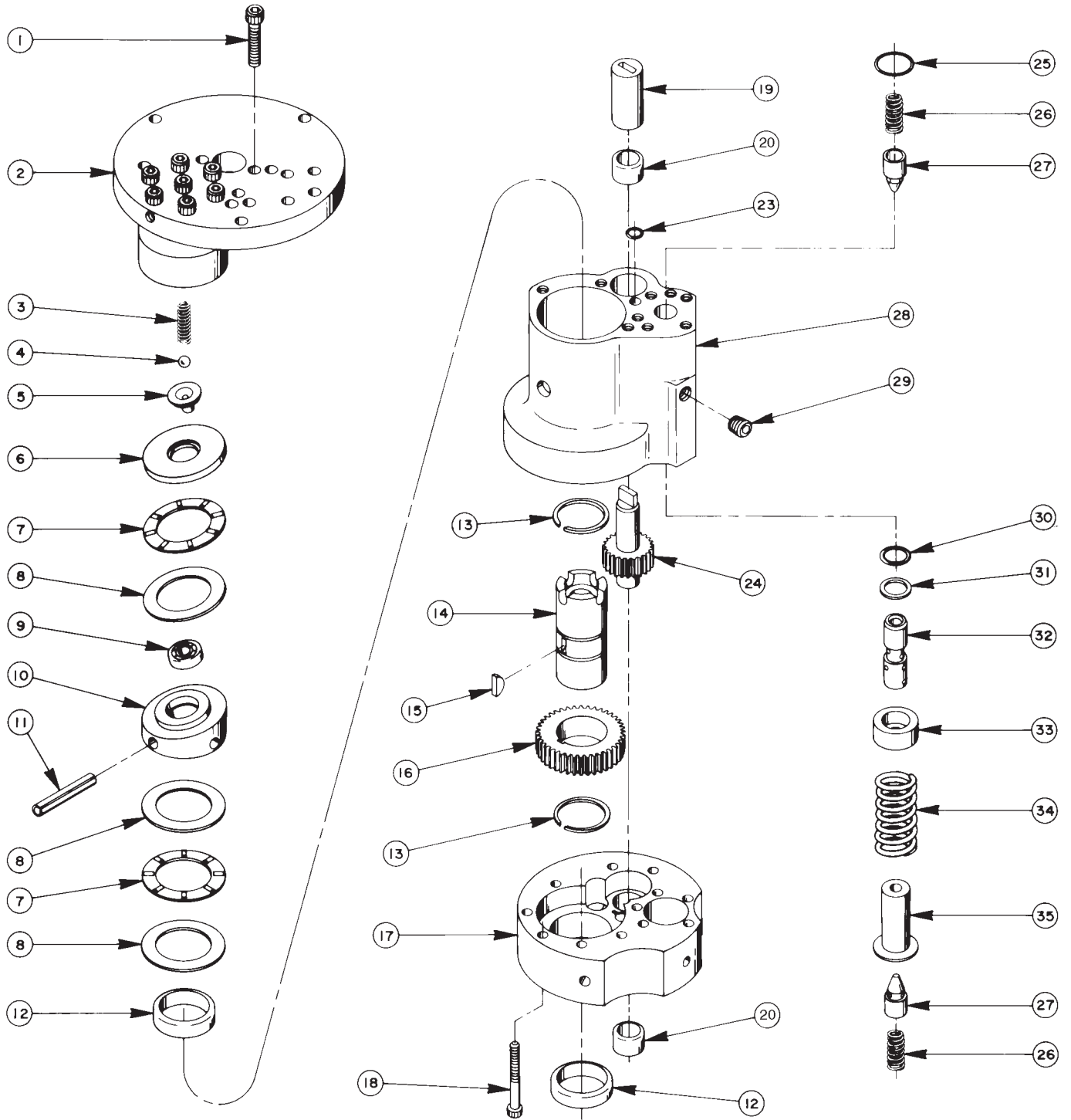

Item No.	Part No.	No. Req'd	Description
1	10020	9	Soc. Hd. Cap Screw (1/4-20 X 1-1/4 Lg.; Torque to 170-180 in. lbs.)
2	33113	1	High Pressure Pump Ass'y (See back sheet 5 of 6)
3	10361	1	Compression Spring (1/4 O.D. X 1" Lg.)
4	10375	1	Steel Ball (1/4 Dia.)
5	23547	1	Bearing Top Plate
6	23548	1	Top Plate
7	11228	2	Thrust Bearing
8	11813	3	Bearing Race
9	11814	1	Ball Bearing
10	23549	1	Angle Plate
11	11955	1	Roll Pin (1/4 Dia. X 3/4 Lg.)
12	11064	2	Needle Bearing
13	11261	2	Retaining Ring (1-1/8 Shaft)
14	23556	1	Shaft
15	11821	1	Woodruff Key
16	23557	1	Gear
17	30533	1	Pump End Plate
18	10001	12	Soc. Hd. Cap Screw (10-32 X 1-3/4 Lg.; Torque to 50 in. lbs.)
19	21091	1	Aluminum Coupling
20	11199	2	Needle Thrust Bearing (See diagram below)
23	10266	1	O-ring (1/4 X 3/8 X 1/16)
24	21272	1	Drive Gear
25	10303	1	O-ring (7/8 X 3/4 X 1/16)
26	10425	2	Compression Spring (3/8 O.D. X 3/4 Lg.)
27	20771	2	Poppet
28	40120	1	Pump Body
29	10427	1	Pipe Plug (1/8 NPTF)
30	10271	1	O-ring (11/16 x 1/2 X 3/32)
31	12389	1	Teflon Backup Washer (11/16 X 1/2 X 1/16)
32	20849	1	Spool
33	23255	1	Spring Guide
34	10426	1	Compression Spring (1" O.D. X 1-13/16 Lg.)
35	23256	1	Spring Guide

NEEDLE BEARING INSTALLATION SPECIFICATIONS

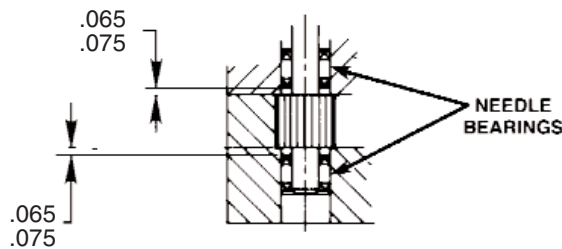

When replacing the needle bearings on the drive gear of the basic pump, the dimensions shown must be as specified.

HIGH PRESSURE PUMP ASSEMBLY

See Diagram
on Reverse
Side for
Important
Ass'y.
Information

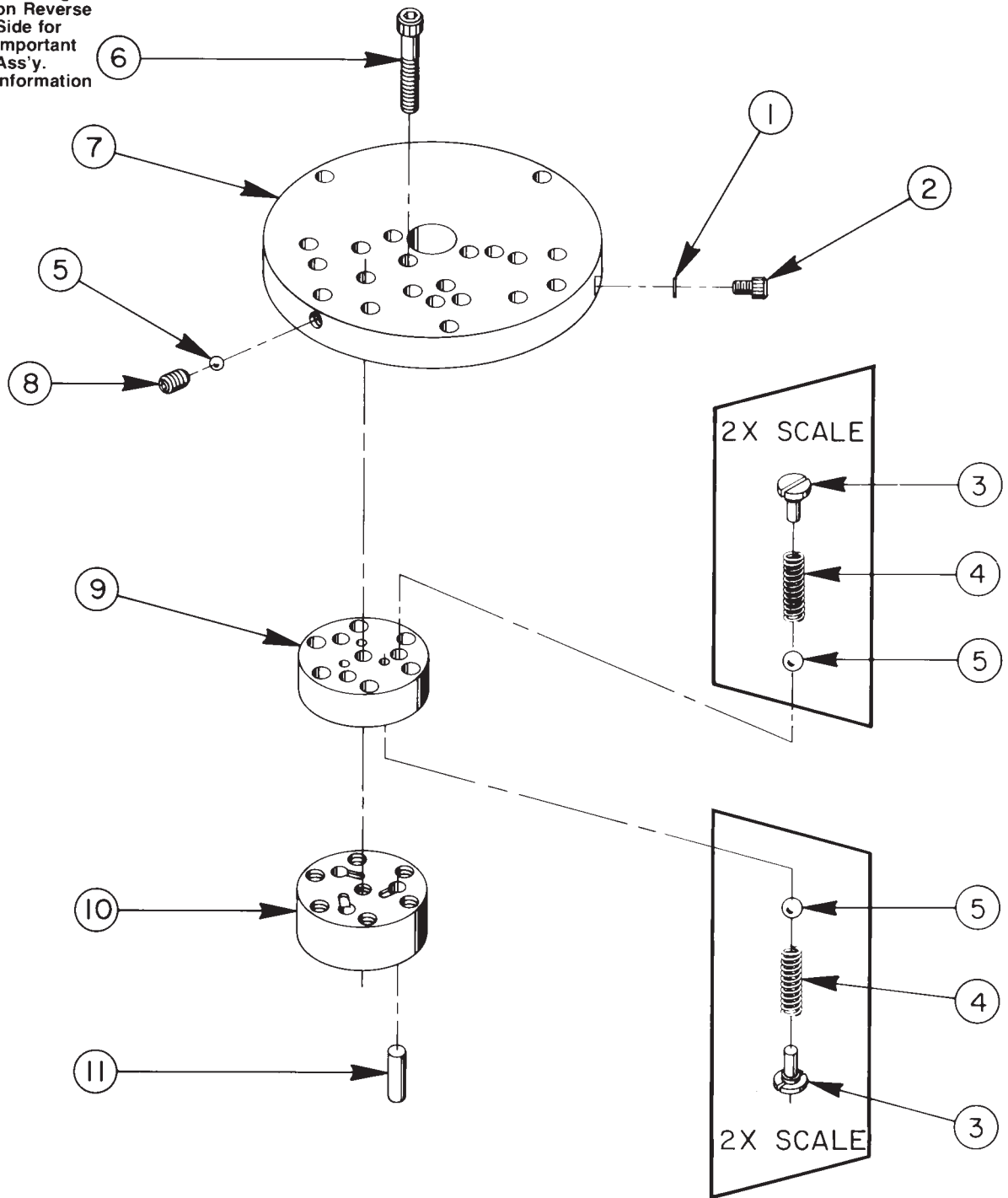

#33113 HIGH PRESSURE PUMP ASS'Y
(3 Pistons - 9/32 Dia.)

Item No.	Part No.	No. Req'd	Description
1	10442	1	Copper Washer (3/8 X 1/4 X 1/32)
2	10002	1	Soc. Hd. Cap Screw (1/4-20 NC X 3/8 Lg.; Torque to 140/160 in. lbs.)
3	*24549	6	Valve Guide
4	*10445	6	Compression Spring (.164 O.D. X .718 Lg.)
5	*12223	7	Steel Ball (3/16 Dia.)
6	*10023	7	Soc. Hd. Cap Screw (1/4-28 NF X 1-1/2 Lg.; Torque to 170/180 in. lbs.)
7	*50411	1	Top Plate (Aluminum)
8	10519	1	Soc. Set Screw (1/4-28 NC x 3/8 Lg.; Torque to 65/70 in. lbs.)
9	*40630	1	Valve Head
10	*41062	1	Pump Barrel
11	*21628	3	Piston

Consult factory when replacing items marked with an asterisk (*).

BOLT TIGHTENING SEQUENCE

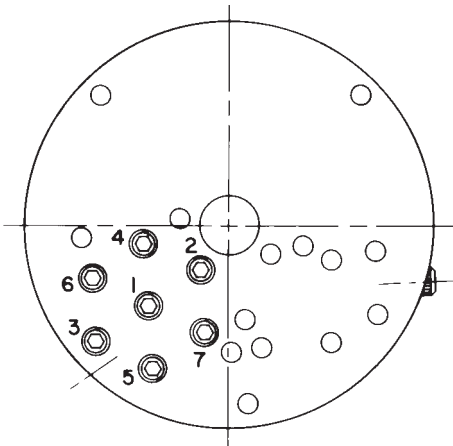

NOTE: Assemble in sequence shown. Lubricate under head and on threads. Torque to 180 in. lbs.

Refer to any operating instructions included with this product for detailed information about operation, testing, disassembly, reassembly, and preventive maintenance.

Items found in this parts list have been carefully tested and selected. **Therefore: Use only genuine Power Team replacement parts!**

Additional questions can be directed to our Technical Services Department.

HAND CONTROL ASSEMBLY

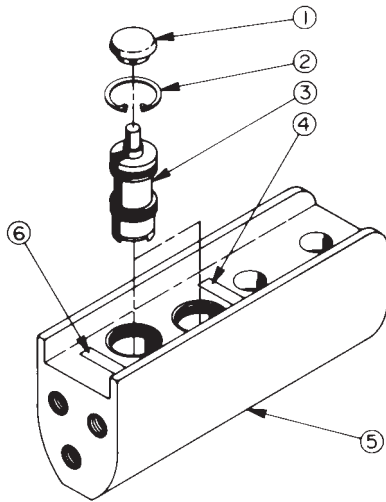

Item No.	Part No.	No. Req'd	Description
1	206105	2	Push Button
2	11033	2	Retaining Ring
3	206104	2	Valve Cartridge (Including seals)
4	203769	2	Decal (Stop)
5	421265	1	Control Valve Body (Includes items 1, 2, & 3)
6	203770	1	Decal (Run)

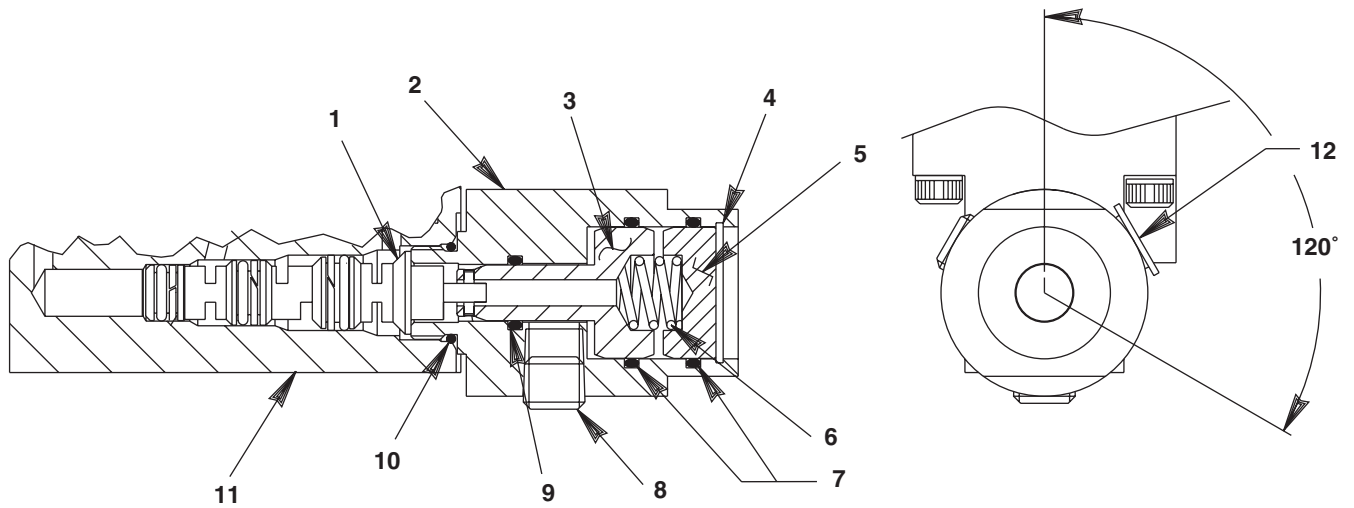

DIRECTIONAL VALVE

Item No.	Part No.	No. Req'd	Description
1	351232	1	Valve, Spool
2	421249	1	Body, Valve
3	351231	1	Piston
4	16686	1	Ring, Retain Int 0.88 x .042
5	252105	1	Piston
6	11195	1	Spring (.49 OD X .75 X .05 WS)

Item No.	Part No.	No. Req'd	Description
7	10304	2	O-Ring Nitrile (-020) Nitrile .1 x .87
8	251279	2	Fitting, Plug (1/8 PTF)
9	10268	1	O-Ring Nitrile (-012) Nitrile .50 x .37
10	10301	1	O-Ring Nitrile (-014) Nitrile .62 x .50
11	3000167BK	1	Valve, Solenoid 3-Way open ctr.
12	15697	1	Cap, Plastic

**BASIC PUMP ASSEMBLY
(BOTTOM VIEW)**

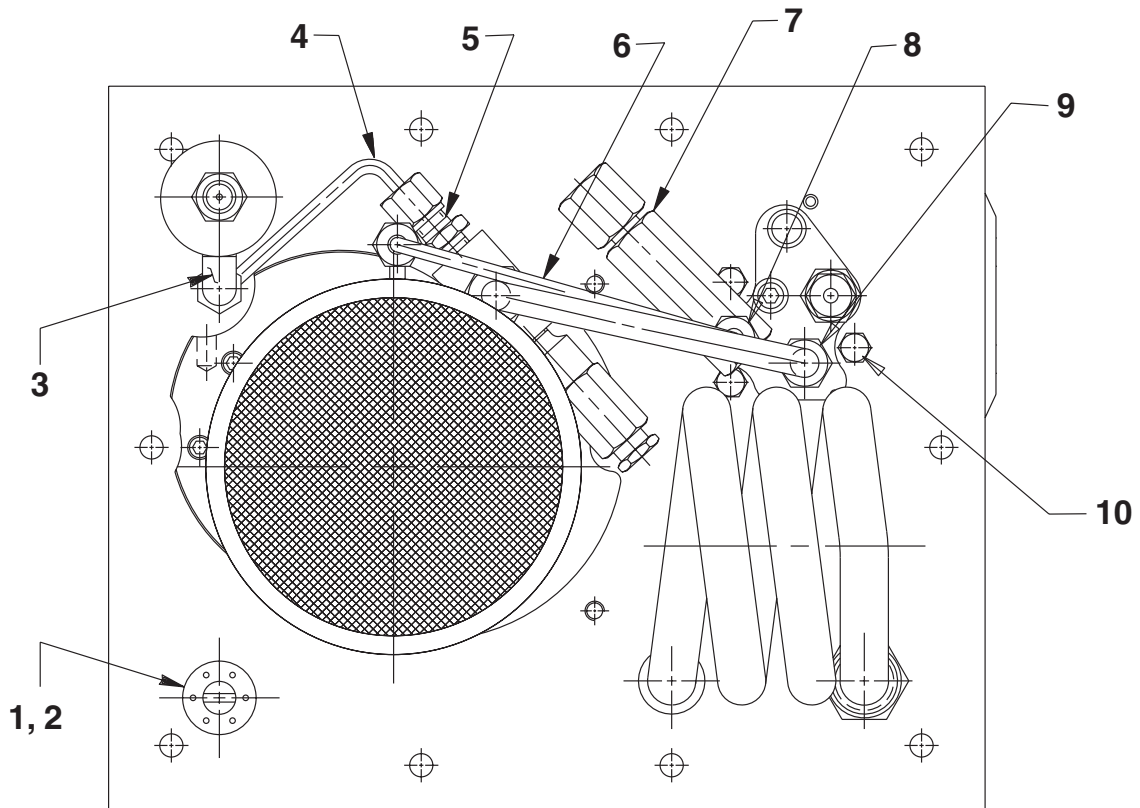

Item No.	Part No.	No. Req'd	Description
1	20937	1	Vent Cap
2	200415	1	O-ring (13/16 X 5/8 X 3/32)
3	16177	1	90° Elbow Fitting
4	201570	1	Pressure Regulator Tube
5	14844	1	Straight Fitting
6	252118	1	Oil Line
7	21943	1	Accumulator
8	11173	1	Straight Fitting
9	10661	1	Straight Fitting
10	10008	3	Hex Hd. Cap Screw (1/4-20 UNC X 5/8 Lg.)